

# Harmonic Drive Gearing

## Quantum CSG Series: Gearhead

Harmonic Drive Gearing Options ▼



### List of Features

CSG series harmonic drive gearheads, which are improved versions of the CSF series, are designed for high-torque operation.

Based on the development concepts of upgrading the load capacity, strength reliability and extending the service life, CSG series has been improved further in respect to the following performance characteristics as compared to CSF series products of the same size:

- Rated torque improved 30%
- Repeated Peak torque improved 30%
- Max. momentary torque improved 30%
- Ratcheting torque improved 30%
- Rated service life extended 42% (to 10,000 hours)
- In respect to external dimensions, rigidity, angle transmission accuracy, input moment of inertia, etc., CSG series Gearheads products are the same as CSF series gearheads.

### List of Ratings

Model No.	Gear ratio	Rated Torque at 2000 rotations/min		Repeated peak torque		Max. average load torque		Max. momentary torque	
		N•m	kgf•m	N•m	kgf•m	N•m	kgf•m	N•m	kgf•m
14	50	7.0	0.7	23	2.3	9.0	0.9	46	4.7
	80	10	1.0	30	3.1	14	1.4	61	6.2
	100	10	1.0	36	3.7	14	1.4	70	7.2
17	50	21	2.1	44	4.5	34	3.4	91	9.0
	80	29	2.9	56	5.7	35	3.6	113	12
	100	31	3.2	70	7.2	51	5.2	143	15
	120	31	3.2	70	7.2	51	5.2	112	11
20	50	32	3.3	73	7.4	45	4.6	127	13
	80	45	4.6	96	9.8	61	6.2	166	17
	100	52	5.3	107	11	64	6.5	191	19
	120	52	5.3	113	12	64	6.5	191	19
	160	52	5.3	120	12	64	6.5	191	19
25	50	51	5.2	127	13	72	7.3	245	25
	80	81	8.3	176	18	118	12	333	34
	100	86	8.8	206	21	137	14	372	38
	120	86	8.8	216	22	137	14	392	40
	160	86	8.8	225	23	137	14	412	42
	50	98	10	284	29	137	14	500	51
	80	157	16	392	40	216	22	735	75

32	100	176	18	431	44	284	29	843	86
	120	176	18	461	47	284	29	892	91
	160	176	18	480	49	284	29	892	91
40	50	176	18	519	53	255	26	892	91
	80	265	27	676	69	372	38	1274	130
	100	343	35	735	75	480	49	1401	143
	120	382	39	804	82	588	60	1529	156
	160	382	39	843	86	588	60	1529	156

## Product Drawing

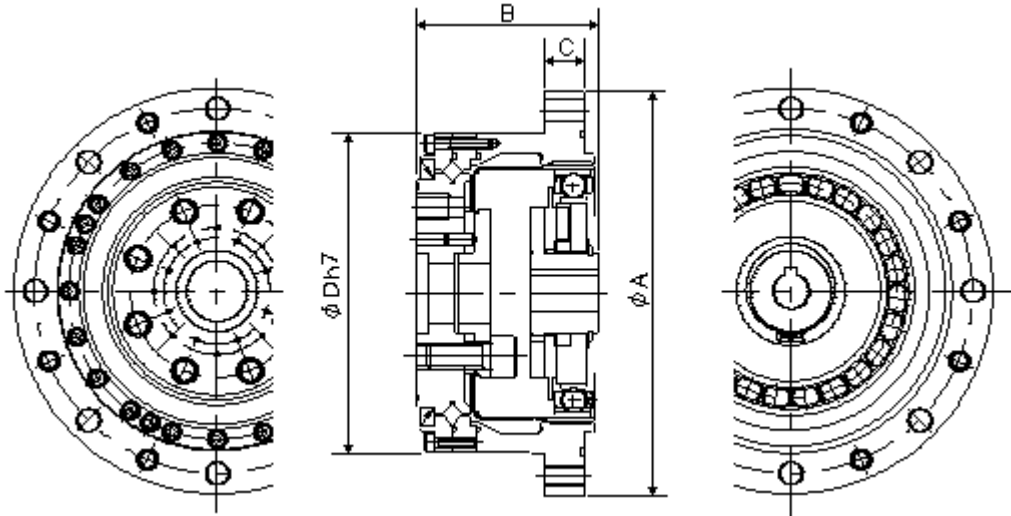

## List of Dimensions

Unit: mm

Model No. Symbol	14	17	20	25	32	40
φ A	73	79	93	107	138	160
B	41	45	45.5	52	62	72.5
C	7	8	10	10	12	16
φD h7	56	63	72	86	113	127

Sold & Serviced By:

**ELECTROMATE**

Toll Free Phone (877) SERV098

Toll Free Fax (877) SERV099

[www.electromate.com](http://www.electromate.com)

[sales@electromate.com](mailto:sales@electromate.com)